

Perspective View

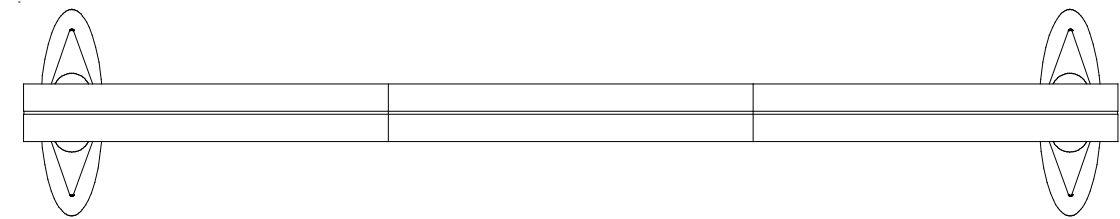

Top View

SETUP INSTRUCTIONS

General Setup Instructions

- Read entire setup instruction manual prior to unpacking parts and pieces.
- The setup instructions are created specifically for this configuration.
- Setup instructions are laid out sequentially in steps, including exploded views with detailed explanation for assembly.

Cleaning & Packing

- For Cleaning Metal, Plex, & Laminate Parts: Use a **MILD NON-ABRASIVE** cleanser and soft cloth/paper towel to clean all surfaces.
- Keep exhibit components away from heat and prolonged sun exposure. **Heat and UV exposure will warp and fade components.**
- Retain all provided Packing Materials. All provided packing materials are for ease of repacking & component protection.

Disassembly

- For loss prevention, tighten all set screws and locks during disassembly.

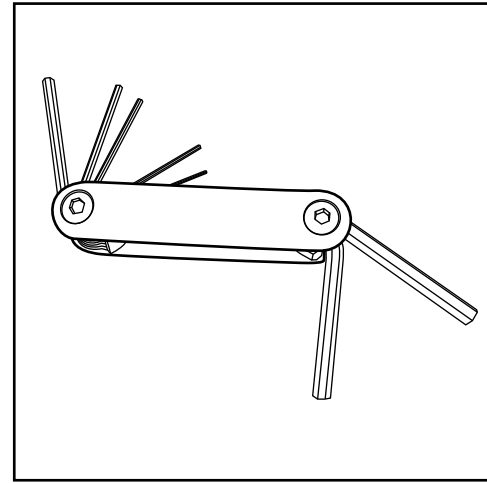

Hex Tool - Essential for Assembly

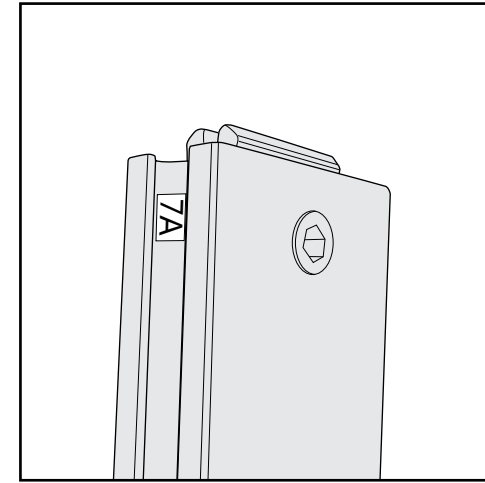

Part Identification - Numbering

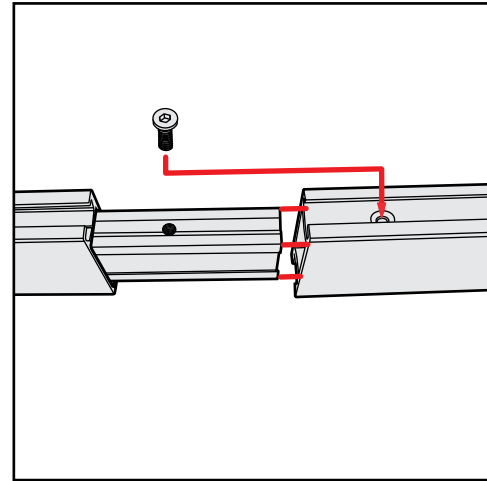

Spline Connection

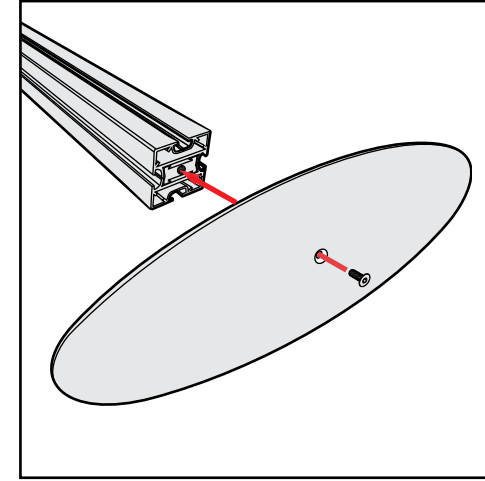

Base Plate & Extrusion Connection

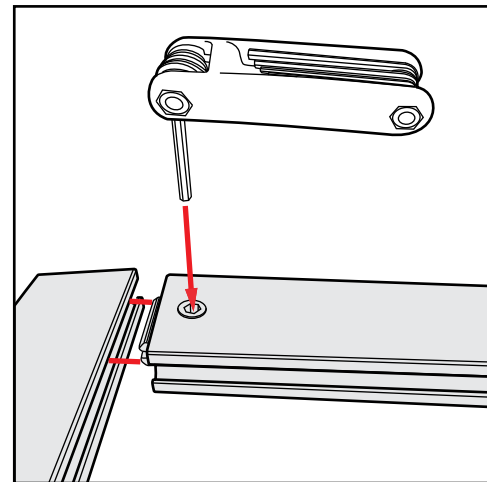

Extrusion & Lock Connection

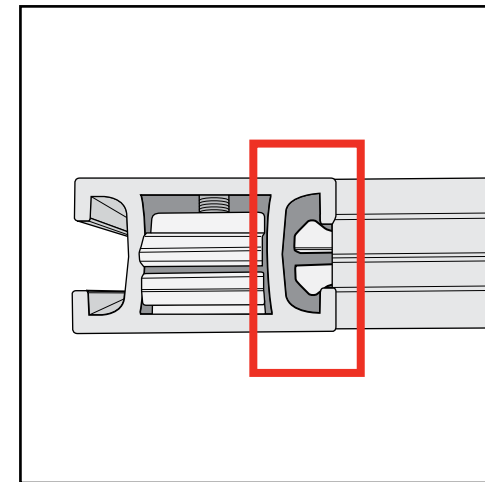

Engaged Lock



WARNING



DO NOT USE POWER TOOLS

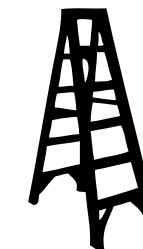

LADDERS OR LIFTS
MAY BE REQUIRED



ALL CONNECTIONS MUST
BE TIGHTLY SECURED

Straight Connection

When assembling frame, first attach all **straight connectors**, then attach **corner connectors**.

- 1) Place extrusions end-to-end.
- 2) Loosen all knobs, then slide **straight connectors** across the seam of extrusions.
- 3) Tighten all knobs to secure connection.

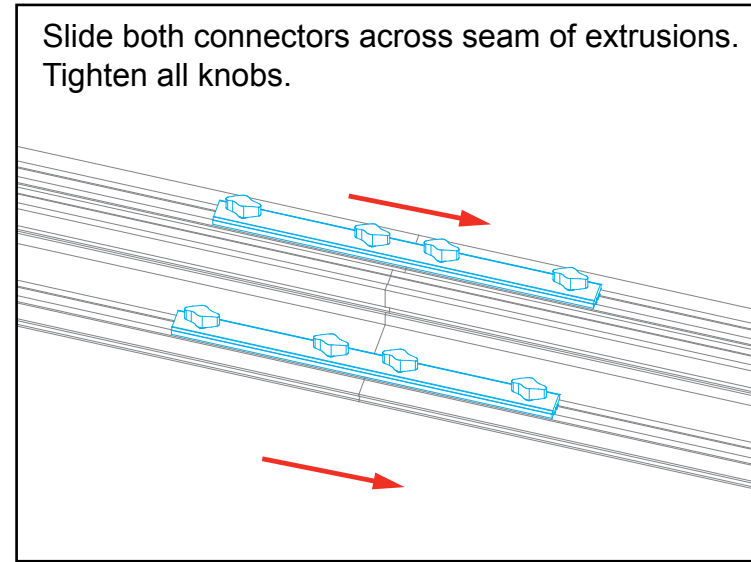
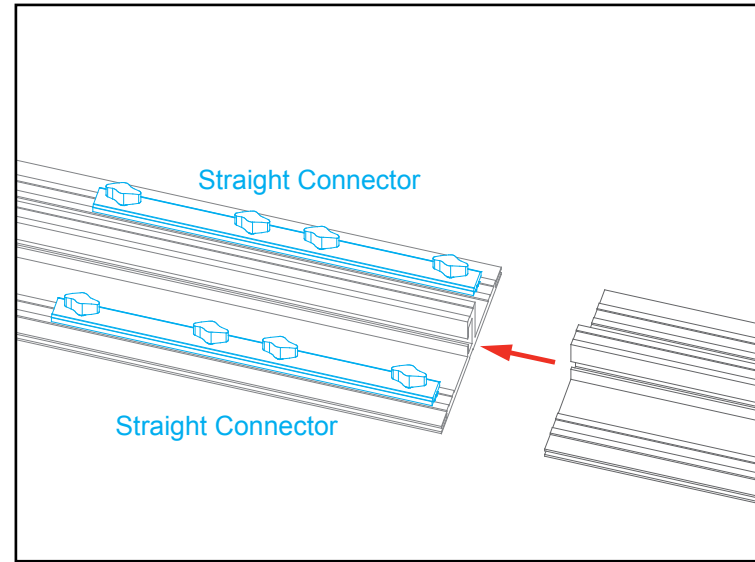

All knobs must be tightened securely to ensure a proper connection.

Disassembly

- 1) Loosen all knobs.
- 2) Slide connectors off of one extrusion.
- 3) Tighten knobs to prevent loss during packing & shipping.

Keep straight connectors in groove of extrusion. Do not remove connectors during disassembly.

Corner Connection

- 1) Loosen knobs, then slide vertical extrusions onto **corner connectors** of **lower** horizontal extrusion.
- 2) Slide **corner connectors** of **upper** horizontal extrusion into grooves of vertical extrusions.
- 3) Tighten all knobs to secure connection.

Disassembly

- 1) Loosen knobs on vertical extrusions.
- 2) Slide the vertical extrusions off of **corner connectors** on lower and upper horizontal extrusions.

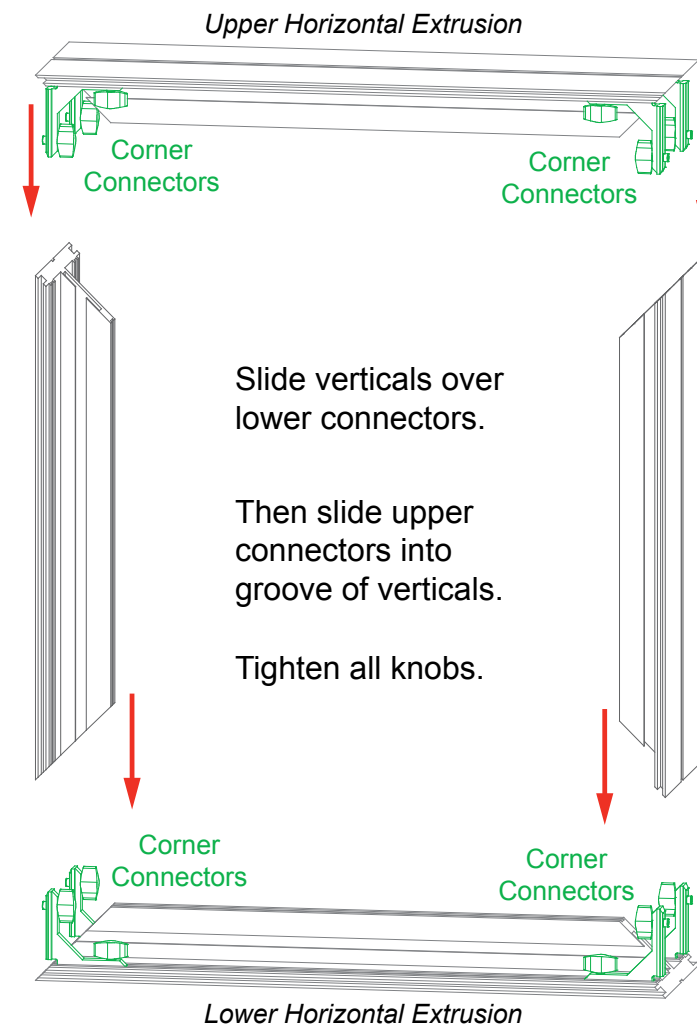

Adjust connectors if necessary to prevent gaps in connection.

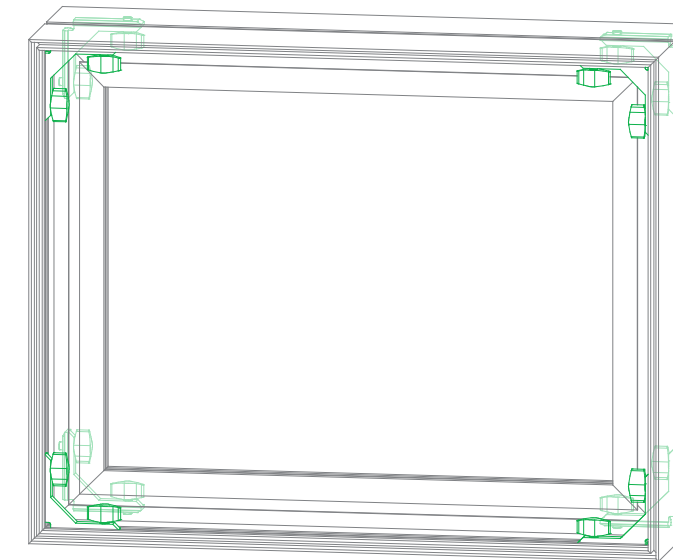

COMPLETED ASSEMBLY

All knobs must be tightened securely to ensure a proper connection.

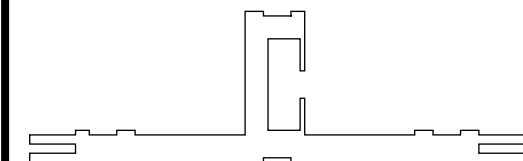

CEI152 Profile

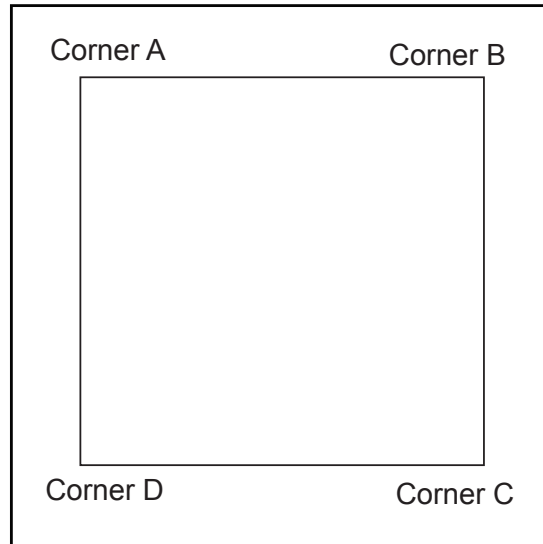

It is important to first insert graphic into each alternate corner then to the sides of the frame. If this is not done, graphic will not fit into the frame correctly.

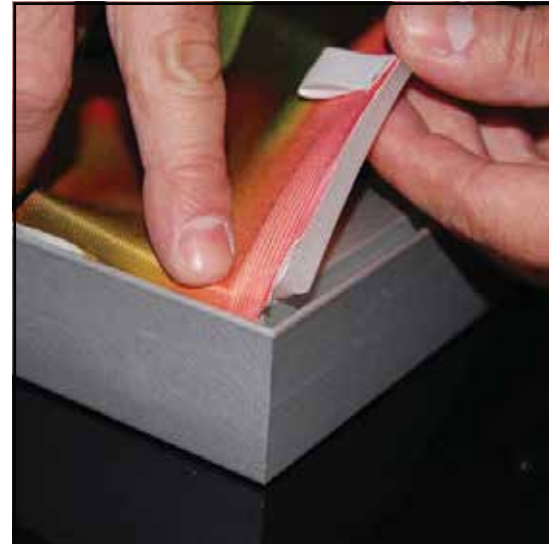

Step 1
Insert corner A. Turn edge of graphic so silicon welt is perpendicular to face of graphic. Insert narrow side of welt with fabric to outside into the channel. Repeat for other side of this corner.



Step 2
Repeat Step 1 for opposite corner C, then insert corner B, followed by corner D, to complete the installation of the corners.



Step 3
Once all corners are inserted, press one silicon edge into channel from corners and work toward the center. Make sure welt is fully inserted into channel. Continue until all sides are done. Smooth out edges of graphic.

Graphic Removal

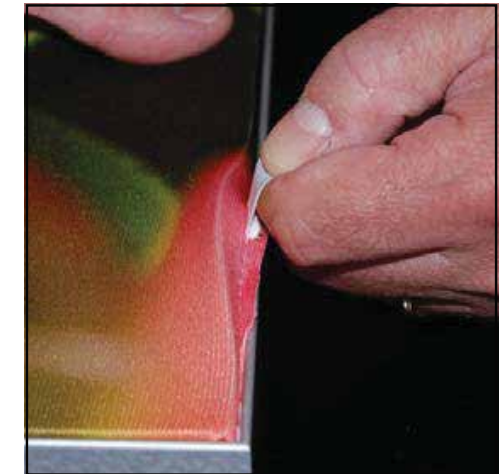

To remove the graphic from the frame, locate the fabric pull tab. Gently pull up on the tab to remove the fabric.

Item	Qty.	Description
1	2	Base Plate
2,2A	1,1	38" CEI152 Horizontal Extrusion
3,3A	1,1	38" CEI152 Horizontal Extrusion
4,4A	1,1	38" CEI152 Horizontal Extrusion
5,5A	1,1	47.5" CEI152 Vertical Extrusion
6,6A	1,1	47.5" CEI152 Vertical Extrusion
7,7A	1,1	45.6767" Z45 Vertical Extrusion

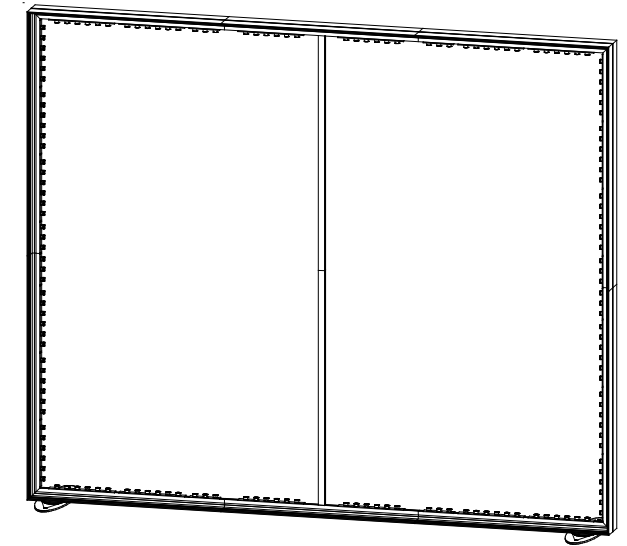

Completed Assembly

Light to Light Attachment

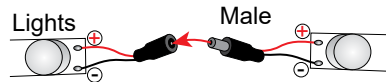

Light to Transformer Attachment

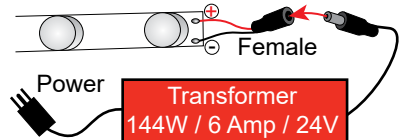

Maximum of 7 lights per chain,
11 lights per Transformer

* Z45 Attachment

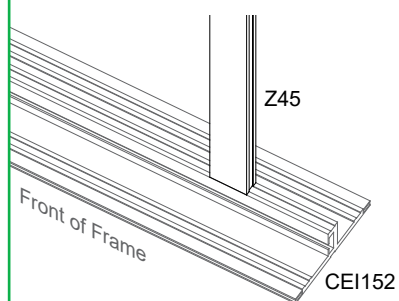

Attach Z45 vertical to *middle*
groove of CEI152 horizontal.

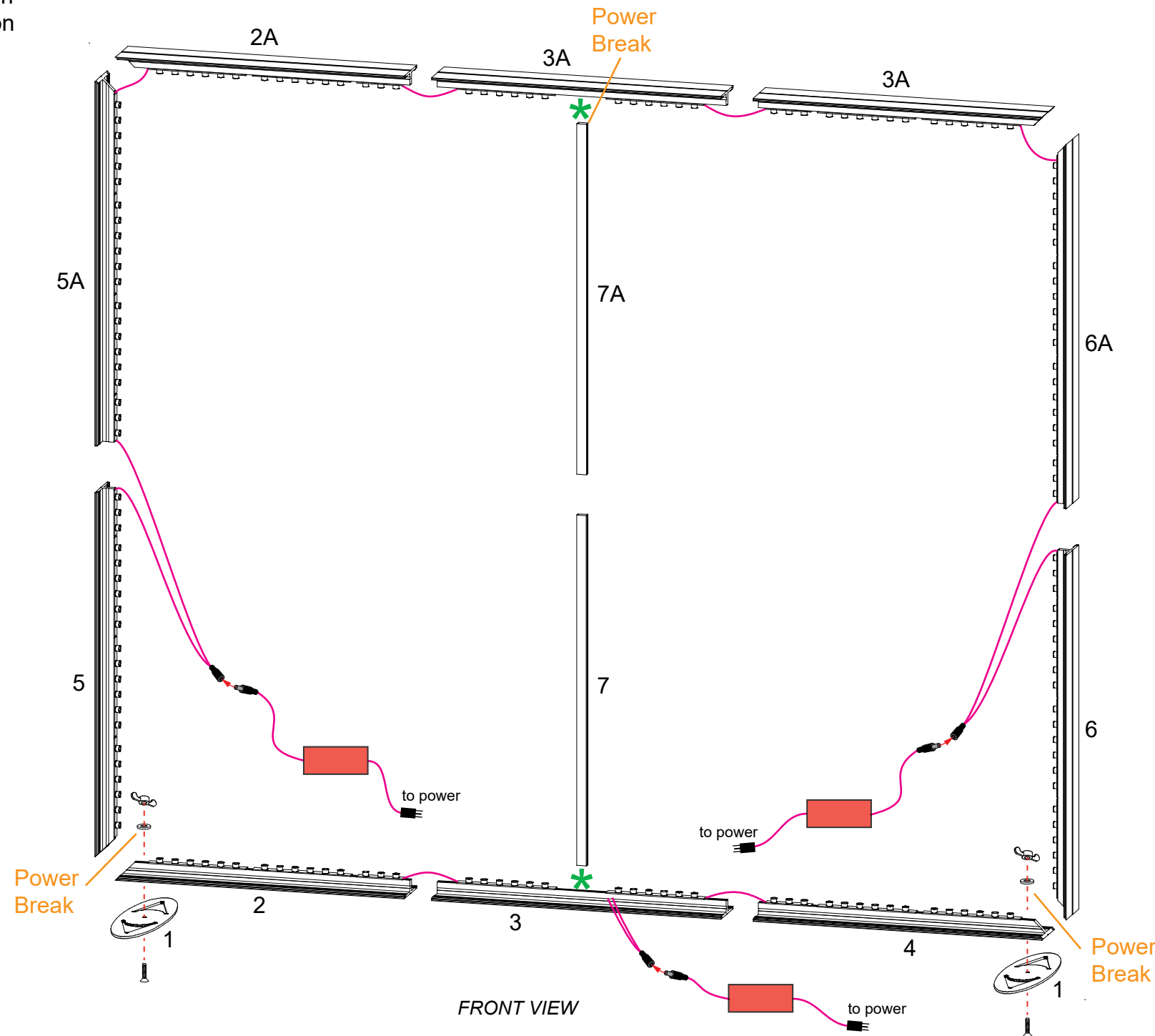

Steps:

Refer to the CEI110 Frame Assembly general information page.

- 1) Assemble horizontals [2-3-4], [2A-3A-4A] & verticals [5-5A], [6-6A], [7-7A] together using straight connectors.
- 2) Connect vertical assemblies [5/5A], [6/6A] between horizontal assemblies [2/3/4], [2A/3A/4A] using corner connectors.
- 3) Attach verticals [7/7A] between horizontal assemblies. See Z45 Attachment detail.
- 4) Connect Base Plates [2] to horizontals [2,4], using bolts.
- 5) Attach power cords to Supernova lights as shown.
- 6) Apply SEG Graphics to assembled frame.
Refer to the SEG Installation general information page.

Assemble frame flat on ground.